

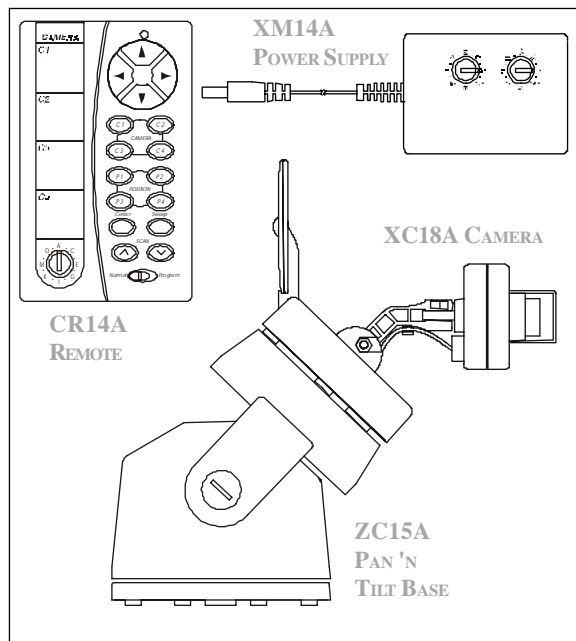

OWNER'S MANUAL



MODEL VK75A PAN 'N TILT CAMERA SYSTEM

INCLUDES ZC15A PAN 'N TILT BASE, XM14A ADDRESSABLE POWER SUPPLY, CR14A REMOTE, AND XC18A CAMERA





INTRODUCTION

The VK75A includes the ZC15A Pan 'n Tilt Camera Base with XM14A remote controlled power supply, the XC18A Wireless Camera, and the CR14A remote control. The wireless camera is attached to the Pan 'n Tilt Camera Base. The camera sends the picture and sound to a receiver that you connect to your TV, up to 100 ft. away. (Receiver sold separately). You can remotely control the camera's position (pan and tilt it) using a CR14A remote control.

FCC CAUTION

THIS DEVICE COMPLIES WITH PART 15 OF THE FCC RULES.

OPERATION IS SUBJECT TO THE FOLLOWING TWO CONDITIONS:

- (1) THIS DEVICE MAY NOT CAUSE HARMFUL INTERFERENCE, AND
- (2) THIS DEVICE MUST ACCEPT ANY INTERFERENCE RECEIVED, INCLUDING INTERFERENCE THAT MAY CAUSE UNDESIRE OPERATION.

This equipment generates and uses radio frequency energy, and if not installed and used properly, that is, in strict accordance with the manufacturers instructions, it may cause interference to radio and television reception. It has been type tested and found to comply with the limits for remote control devices in accordance with the specifications in Sub-Parts B and C of Part 15 of FCC Rules, which are designed to provide reasonable protection against such interference in a residential installation. However, there is no guarantee that interference will not occur in a particular installation. If this equipment does cause interference to radio or television reception, which can be determined by unplugging the equipment, try to correct the interference by one or more of the following measures.

- Reorient the antenna of the radio/TV experiencing the interference.
- Relocate the equipment with respect to the radio/TV.
- Move the equipment away from the radio/TV.
- Plug the equipment into an outlet on a different electrical circuit from the radio/TV experiencing the interference.
- If necessary, consult your local Dealer for additional suggestions.

NOTE: Modifications to this product will void the user's authority to operate this equipment.



CONTENTS

<i>CONTROLS AND CONNECTIONS</i>	4
<i>PAN 'N TILT BASE WITH CAMERA AND POWER SUPPLY</i>	4
<i>RECEIVER</i>	5
<i>CONNECTING UP</i>	6
<i>CONNECTING UP THE PAN 'N TILT BASE AND CAMERA</i>	6
<i>CONNECTING UP THE RECEIVER</i>	9
<i>REMOTE CONTROL</i>	10
<i>INSTALLING THE BATTERIES</i>	10
<i>SINGLE CAMERA OPERATION</i>	11
<i>STORING SWEEP POSITIONS</i>	11
<i>CLEARING ALL STORED POSITIONS</i>	11
<i>CENTERING</i>	11
<i>SWEEPING</i>	11
<i>STOPPING A SWEEP</i>	11
<i>TURNING THE CAMERA OFF</i>	11
<i>MULTI-CAMERA SYSTEMS</i>	12
<i>INSTALLING A TRANSCEIVER</i>	12
<i>TURNING CAMERAS ON AND OFF</i>	12
<i>STORING SWEEP POSITIONS</i>	13
<i>CLEARING ALL STORED POSITIONS</i>	13
<i>CENTERING</i>	13
<i>SWEEPING</i>	14
<i>STOPPING A SWEEP</i>	14
<i>TO CHANGE THE CODES THAT C1 THRU C4 CONTROL</i>	14
<i>TROUBLESHOOTING</i>	15
<i>WARRANTY</i>	19

CONTROLS AND CONNECTIONS

Point the raised dimple on the antenna towards the Receiver's location.

Set channel switch (under rubber plug) to match setting on VR31A or VR36A Receiver. (A is at bottom, D is at top). It is factory set to A.

XC18A camera.

ZC15A Pan 'n Tilt Base.

Remove clear cap and turn lens counterclockwise to focus (replace cap for outdoor use).

Attach to a wall using mounting bracket (supplied).

Outdoors

Indoors

Plug power supply in here.

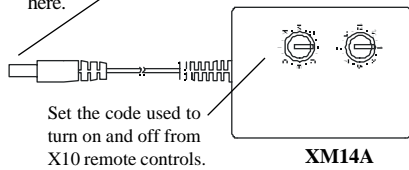

XM14A

4

VR36A VIDEO RECEIVER (SOLD SEPARATELY)

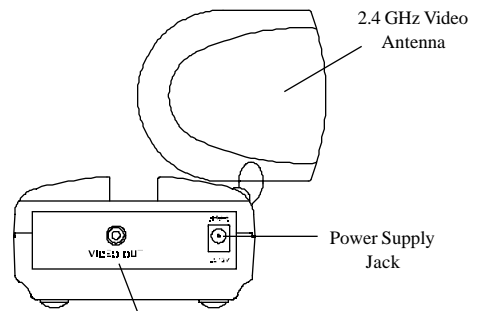

Video Out Jack

2.4 GHz Channel Switch

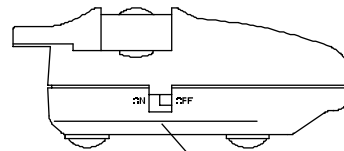

ON-OFF Switch

5

CONNECTING UP

ATTACH THE CAMERA TO THE PAN 'N TILT BASE, THEN ATTACH THE BASE TO THE MOUNTING BRACKET, THEN ATTACH THE BRACKET TO A WALL.

The camera included with the VK75A is already attached to the Pan 'n Tilt Base for your convenience. If however you want to remove the camera for any reason, please see the following instructions to reattach it.

1. Remove the top from the Pan 'n Tilt base, position the camera with its cable at the front of the top housing (where the notch for the cable is) and attach the camera to the housing using the screws provided.
2. Remove the spindle attached on the inside of the top housing, neatly coil the camera wire into the spindle.
3. Put the coiled spindle back into the top housing and use the supplied washer head screw to attach it in the housing.
4. Plug the power jack from camera into the jack on the Pan 'n Tilt base, and put the jacks into the top housing. (Only Instant-On cameras fit).
5. Attach the top housing to the Pan 'n Tilt base, make sure the front of the housing goes to the front of the Pan 'n Tilt base.

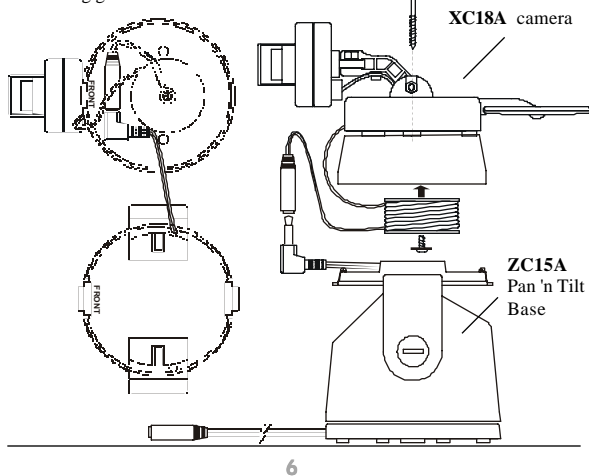

6

6. Attach the Pan 'n Tilt base to the mounting bracket.
7. Install the complete assembly in a suitable location. If you install it outdoors, run the jack through a hole in the wall, or through a window, so you can plug the power supply into an AC outlet indoors.

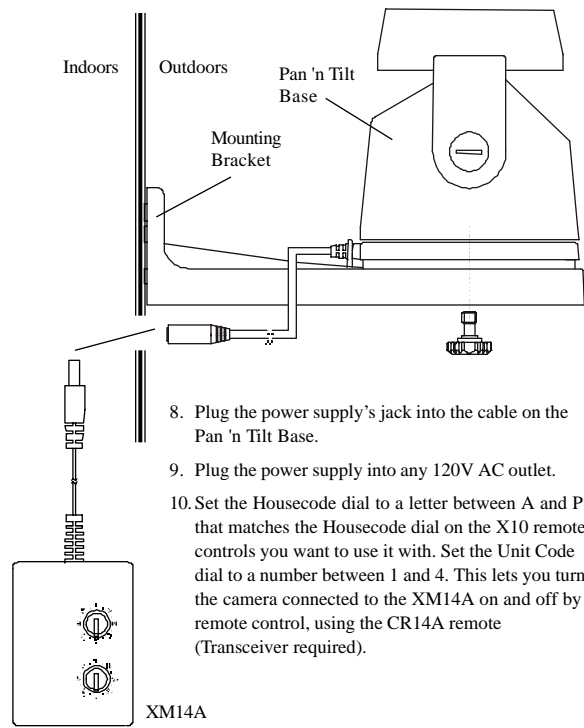

8. Plug the power supply's jack into the cable on the Pan 'n Tilt Base.
9. Plug the power supply into any 120V AC outlet.
10. Set the Housecode dial to a letter between A and P that matches the Housecode dial on the X10 remote controls you want to use it with. Set the Unit Code dial to a number between 1 and 4. This lets you turn the camera connected to the XM14A on and off by remote control, using the CR14A remote (Transceiver required).

XM14A

7

11. Set the channel switch on the camera to the same setting as the one on the VR31A or VR36A Video Receiver (A, B, C, or D).
12. Adjust the antenna if necessary to aim it in the direction of the TV that you will view the camera on.

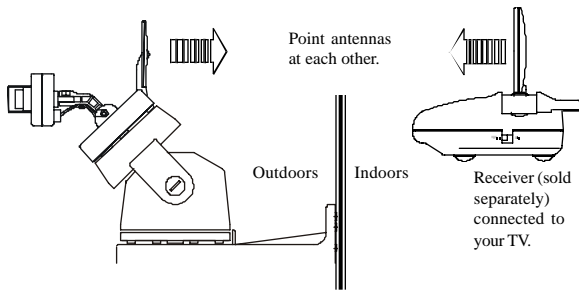

Set up additional cameras if you want (up to 4). Set each camera to the same channel as the Receiver (A, B, C, or D). Set each power supply to a different number within one of the groups (1-4, 5-8, 9-12, or 13-16).

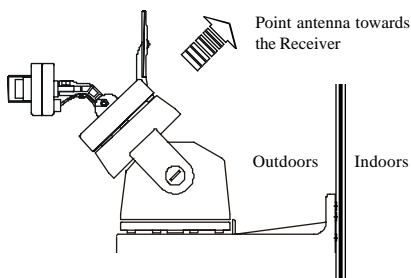

8



RECEIVER

HOOKING UP THE VR36A VIDEO RECEIVER (SOLD SEPARATELY)

1. Connect a Video cable to the VIDEO OUT jack on the Video Receiver. Connect the other end to your TV's VIDEO IN jack. If your TV does not have a Video IN jack, you will need to purchase an RF modulator, or connect as shown in the diagram below.
2. Plug the Video Receiver's Power Supply jack (the power supply with NO code wheels) into the Video Receiver and plug the power supply into a 120 volt wall outlet.
3. Turn the Video Receiver's power switch (on side of unit) on.
4. Set the channel switch to the same letter as you set on the Camera, A, B, C, or D.
5. Position the Video Receiver in a convenient location such as on top of the TV and orient the antenna so that the flat side points in the direction of the room where you set up the Camera.

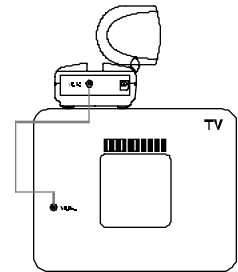

IF YOUR TV IS ALREADY HOOKED UP TO A DBS RECEIVER OR OTHER A/V DEVICE, OR IF YOUR TV DOES NOT HAVE A VIDEO IN JACK

If a DBS Receiver or other A/V component is connected to the TV using A/V cables, you can connect the Video Receiver to the free LINE IN jacks on the component.

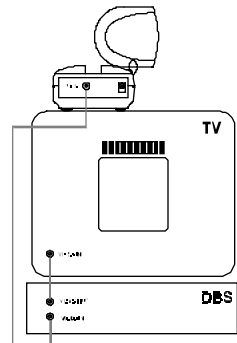

9

REMOTE CONTROL

The Remote lets you move the camera from left to right (Pan) and up and down (Tilt). You can store 4 positions for the camera and use the remote to "Sweep" between these positions.

Install 4 AAA alkaline batteries (sold separately) in the remote's battery compartment.

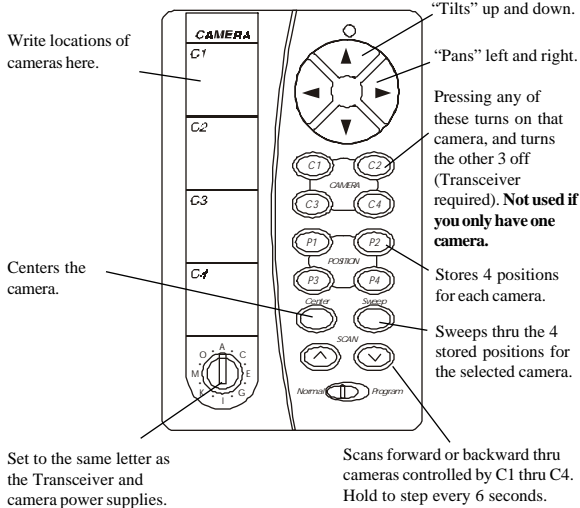

If you purchase multiple Pan 'n Tilt Cameras, and purchase a Transceiver (RR501 or TM751) the Remote lets you turn on any of 4 cameras or scan each of them in turn (forward or backward) so as to display the image from each camera in turn on your TV. You connect each camera (up to 4) to its own Pan 'n Tilt Base, plug each one into an Addressable Power Supply, and set each to a different number between 1-4, 5-8, 9-12, or 13-16

SINGLE CAMERA OPERATION

Press a left or right BLUE button at the top of the CR14A Remote to "Pan" the camera left or right. Press a BLUE up or down button to "Tilt" the camera up or down.

Buttons P1 thru P4 are used to store 4 position settings for the camera.

1. To store the first position for the camera, press the BLUE buttons to scan to the position you want. Move the switch at the bottom from Normal to Program. Press P1.
2. To store the second position for the camera, press the BLUE buttons to scan to the position you want. Move the switch at the bottom from Normal to Program. Press P2.
3. To store the third position for the camera, press the BLUE buttons to scan to the position you want. Move the switch at the bottom from Normal to Program. Press P3.
4. To store the fourth position for the camera, press the BLUE buttons to scan to the position you want. Move the switch at the bottom from Normal to Program. Press P4. Move the switch back to Normal.

To clear all stored positions:

Move the switch at the bottom to Program. Press **Center** then move the switch back to Normal.

WITH THE SWITCH SET TO NORMAL:

Press P1, P2, P3 or P4 to move to any of the 4 positions stored for the camera.

Press **Center** to center the position for the camera.

Press **Sweep** to sweep through all 4 positions stored for the camera.

To stop scanning or movement to a stored position:

Press any BLUE key on the remote while the camera is moving to stop the movement.

To turn the camera off:

Unplug its power supply. For multiple camera systems a Transceiver is required, which then lets you turn the cameras on and off by remote control.

MULTI-CAMERA SYSTEMS

STOP! If you only own one Pan 'n Tilt Camera, you don't need to read any further.



Important: For a Multi Camera system you will need to install a Transceiver (Model RR501 OR TM751, each sold separately). Set its Housecode to match the CR14A Remote, and XM14A power supplies you've installed.



1. Set Housecode to match the CR14A Remote, and power supplies.



2. Plug the Transceiver into an AC outlet located centrally in your home.

1. To control up to 4 Cameras, plug each one into its own Addressable Power Supply, and set each power supply to the same Housecode you set on the Transceiver and the Remote. Set each power supply to a unique number between 1 and 4. Pressing any Camera button (C1, C2, C3, or C4) turns on that camera (1, 2, 3, or 4) and turns the others (in the group) off. Then, each press of either the  or  button turns on the next or previous camera in the group of 4 while turning the current camera off. You must set all cameras to the same channel as the Video Receiver VR31A, or VR36A (Channel A, B, C, D).
2. To "Pan" or "Tilt" a camera: Press C1, C2, C3, or C4 to turn on the camera. Then press a left or right BLUE button at the top to "Pan" the camera left or right. Press a BLUE up or down button to "Tilt" the camera up or down.



Buttons P1 thru P4 are used to store 4 position settings for each of the 4 cameras controlled by buttons C1 thru C4.

1. Press C1.
2. Move the switch at the bottom from Normal to Program.
3. To store the first position for the camera controlled by C1. Press the BLUE buttons to scan to the position you want. Press P1.
4. To store the second position for the camera controlled by C1. Press the BLUE buttons to scan to the position you want. Press P2.
5. To store the third position for the camera controlled by C1. Press the BLUE buttons to scan to the position you want. Press P3.
6. To store the fourth position for the camera controlled by C1. Press the BLUE buttons to scan to the position you want. Press P4.
7. Move the switch back to Normal.

Press C2 and repeat steps 2 to 7 above to store 4 positions for Camera C2.

Press C3 and repeat steps 2 to 7 above to store 4 positions for Camera C3.

Press C4 and repeat steps 2 to 7 above to store 4 positions for Camera C4.

To clear all stored positions:

Move the switch at the bottom to Program. Press **Center** then move the switch back to Normal.

WITH THE SWITCH SET TO NORMAL:

Press C1, then P1, P2, P3 or P4 to move to camera 1's 4 stored positions.
Press C2, then P1, P2, P3 or P4 to move to camera 2's 4 stored positions.
Press C3, then P1, P2, P3 or P4 to move to camera 3's 4 stored positions.
Press C4, then P1, P2, P3 or P4 to move to camera 4's 4 stored positions.

Press C1 then **Center** to center the position for camera 1.
Press C2 then **Center** to center the position for camera 2.
Press C3 then **Center** to center the position for camera 3.
Press C4 then **Center** to center the position for camera 4.



Press C1 then **Sweep** to sweep through camera 1's 4 stored positions.
Press C2 then **Sweep** to sweep through camera 2's 4 stored positions.
Press C3 then **Sweep** to sweep through camera 3's 4 stored positions.
Press C4 then **Sweep** to sweep through camera 4's 4 stored positions.

To stop a sweep:

If you press C2, C3, or C4 while camera C1 is sweeping, it will continue to sweep. To stop Camera C1, press C1, then press any BLUE key.

To Change which group of 4 cameras you want buttons C1, C2, C3, and C4 to control:

1. To make buttons C1 thru C4 control cameras **5-8** (instead of 1 thru 4) move the switch at the bottom from Normal to Program, press **C2** then move the switch back to Normal.
2. To make buttons C1 thru C4 control cameras **9-12** move the switch from Normal to Program, press **C3** then move the switch back to Normal.
3. To make buttons C1 thru C4 control cameras **13-16** move the switch from Normal to Program, press **C4** then move the switch back to Normal.

Note: pressing C1, C2, C3, or C4, turns on that camera and turns the others in the group off. So you will always have one camera on. The only way to turn ALL the cameras off is to unplug their power supplies.



TROUBLESHOOTING

If you do not see a picture on your TV:

Check that the Receiver and the Camera are on the same letter channel (A, B, C, or D). The channel switch on the Camera is located under the rubber plug on the base of the unit. Make sure you replace the plug afterwards if you intend to use the camera outdoors.

There is a power light on the front of the Receiver. Check that the power switch on the side of the Receiver is ON.

Check that the Camera's remote controlled power supply is turned on (using the CR14A remote control). Note, when you first plug the power supply in, it will normally be ON.

Verify that your connections to the TV are correct. If you are using the RCA jacks, make sure you are using the appropriate input mode for your TV, try pressing the A-B button or Video button on your TV's remote control to change the input mode (consult your TV's owner's manual, if necessary). If you are using the Coax cable (VR31A receiver only), verify that the Receiver and the TV are on the same channel (3 or 4).

If you connected the Receiver to a VCR and then connected the VCR to your TV, you might need to turn the VCR OFF to see the Camera's picture on your TV. Or you might need to turn the VCR on, AND set it to record the picture from the Camera, in order to see the picture on your TV. Or you might need to press the A-B button on your VCR's remote control. Consult your VCR's owner's manual for more information.

If you get a picture but the quality is poor:

Try different positions for the antennas on the Camera and Receiver. Normally they should point at each other. Sometimes, due to reflections, you might get a better picture with the Receiver's antenna pointing to the ceiling.

Take a look at what the video signal is passing through or near to get to the Receiver. Metal objects and electromagnetic fields can distort the signal. Try to keep the Receiver as far away from other devices as the RCA or Coax cables allow. In most cases, relocating the Camera or Receiver a few feet is enough to avoid the source of interference.

Try unplugging/turning off any electromagnetic interference producing devices, such as a microwave oven, baby monitor, computer, wireless LAN, wireless speakers, cordless phone, cell phone, etc.



Other 2.4 GHz devices can distort the Camera's picture and/or cause buzzing in the audio. If you are experiencing interference between X10 Cameras and some other equipment that uses 2.4 GHz, check the other device's owner's manual for the frequencies of each channel that it uses. X10 cameras use the following frequencies: Channel A: 2.411 GHz, Chan B: 2.434 GHz, Chan C: 2.453 GHz, Chan D: 2.473 GHz. We recommend using a frequency on the other device that is farthest from channel A or D, depending on which side of the band the other device is transmitting. Otherwise you will need to discontinue use of the device while using our Cameras.

If the CR14A Pan 'n Tilt Remote doesn't do anything.

Check that the red light on the remote comes on when you press any button. Check that you have the batteries installed correctly, replace if necessary with 4 AAA alkaline batteries.

Check that you have turned the Camera on. For single camera systems the power supply for the Camera will normally be on (it powers up on). For Multi-Camera systems you need to purchase a TM751 Transceiver for the remote to be able to turn the Cameras on. When you turn on any one, in a group of 4, the others in the group turn off. Groups must be 1-4, 5-8, 9-12, or 13-16. Check that all units are set to the same Housecode.

If you are having difficulty turning the Camera on/off remotely:

Plug the Transceiver (the white module with an antenna) into a different outlet. Note a Transceiver (sold separately) is REQUIRED for Multi-Camera systems. If you only have one camera, and don't own a Transceiver, you must unplug the camera's power supply to turn it off.

If the camera is out of focus:

The camera is shipped preset to be in focus for normal use, but if you want to change the focus you can remove the clear plastic cover and rotate the inner portion of the lens. It might be a bit tight. Try turning it counterclockwise first. If you turn it clockwise do not force or over tighten it. Replace the clear plastic cover to keep the rain out.



If cameras are sweeping around their programmed positions fast:

Pressing **Sweep** within 3 seconds of plugging in the camera's power supply enters fast sweep test mode. Turn the camera off to exit the test mode.

If the camera gradually drifts off the positions you have programmed:

This can happen if the positions you programmed do not cause the camera to pass through center. If you notice the positions that you programmed for sweep starting to drift out of position after a while, just press the Center button on the remote to reset the positions to where you programmed them. Or you can make the camera periodically center automatically as follows:

Within 3 seconds after you plug the camera's power supply in, press P1, P2, P3, or P4 on the remote.

Pressing P1 within 3 seconds after you power up forces the camera to re-center every 32 sweeps through the positions you have programmed.

Pressing P2 within 3 seconds after you power up forces the camera to re-center every 64 sweeps through the positions you have programmed.

Pressing P3 within 3 seconds after you power up forces the camera to re-center every 128 sweeps through the positions you have programmed.

Pressing P4 within 3 seconds after you power up forces the camera to re-center every 256 sweeps through the positions you have programmed.

To cancel the above automatic centering:

While the camera is recentering, move the switch on the CR14A remote to Program, press Sweep, and then move the switch back to Normal.

To stop the camera from ever recentering automatically:

Unplug the camera's power supply, plug it back in, and (within 3 seconds) press Center. If the camera was sweeping when you unplugged it, it will continue to sweep when you plug it back in, so you should press any blue key to stop the sweep before you unplug the Camera.





If the image quality changes as the Ninja base rotates:

Since the Ninja rotates the camera, some positions may move the camera's antenna away from the direction of the Video Receiver.

To improve reception:

- Adjust the antenna on the Video Receiver so that the receiving side (the one with the 4 squares on it) points towards the camera.
- Move the camera closer to the Video Receiver.
- Move the Video Receiver as far away from other electronic devices as possible. This can be achieved by using longer audio/video cables between the Video Receiver and TV, VCR, PC, etc.
- Change the frequency by using the A,B,C,D Channel selector switch on the camera and receiver. Make sure both match.
- Unplug other wireless equipment such as wireless intercoms, 2.4 GHz wireless network connections, and 2.4 GHz wireless phones, that could interfere with the signal from the camera.

For more help with setup please visit www.x10.com/support



12 MONTH LIMITED WARRANTY

X10.COM A DIV OF X10 WIRELESS TECHNOLOGY, INC. (X10) WARRANTS ITS PRODUCTS TO BE FREE FROM DEFECTIVE MATERIAL AND WORKMANSHIP FOR A PERIOD OF ONE (1) YEAR FROM THE ORIGINAL DATE OF PURCHASE AT RETAIL. X10 AGREES TO REPAIR OR REPLACE, AT ITS SOLE DISCRETION, A DEFECTIVE X10 PRODUCT IF RETURNED TO X10 WITHIN THE WARRANTY PERIOD AND WITH PROOF OF PURCHASE.

IF SERVICE IS REQUIRED UNDER THIS WARRANTY:

1. CALL 1-800-675-3044, OR VISIT WWW.X10.COM, OR E-MAIL SALES@X10.COM TO OBTAIN A RETURN MERCHANDISE AUTHORIZATION (RMA) NUMBER.
2. RETURN THE DEFECTIVE UNIT POSTAGE PREPAID TO THE ADDRESS BELOW.
3. ENCLOSE A CHECK FOR \$4.00 TO COVER HANDLING AND RETURN POSTAGE.
4. ENCLOSE A DATED PROOF OF PURCHASE.
5. X10 IS NOT RESPONSIBLE FOR SHIPPING DAMAGE. UNITS TO BE RETURNED SHOULD BE PACKED CAREFULLY.

THIS WARRANTY DOES NOT EXTEND TO ANY X10 PRODUCTS WHICH HAVE BEEN SUBJECT TO MISUSE, NEGLIGENCE, ACCIDENT, INCORRECT WIRING OR TO USE IN VIOLATION OF OPERATING INSTRUCTIONS FURNISHED BY US, NOR EXTEND TO ANY UNITS ALTERED OR REPAIRED FOR WARRANTY DEFECT BY ANYONE OTHER THAN X10. THIS WARRANTY DOES NOT COVER ANY INCIDENTAL OR CONSEQUENTIAL DAMAGES AND IS IN LIEU OF ALL OTHER WARRANTIES EXPRESSED OR IMPLIED AND NO REPRESENTATIVE OR PERSON IS AUTHORIZED TO ASSUME FOR US ANY OTHER LIABILITY IN CONNECTION WITH THE SALE OF OUR PRODUCTS.

SOME STATES DO NOT ALLOW LIMITATIONS ON HOW LONG AN IMPLIED WARRANTY LASTS, AND/OR THE EXCLUSION OR LIMITATION OF INCIDENTAL OR CONSEQUENTIAL DAMAGES SO THE ABOVE LIMITATIONS AND EXCLUSIONS MAY NOT APPLY TO THE ORIGINAL CUSTOMER. THIS WARRANTY GIVES YOU SPECIFIC RIGHTS AND YOU MAY ALSO HAVE OTHER RIGHTS WHICH VARY FROM STATE TO STATE.

**X10.com, a division of X10 Wireless Technology, Inc.
(Returns Depot), 3824 North 5th St., Suite C,
North Las Vegas, NV 89032**





**X10.com, a division of X10 Wireless Technology, Inc.
(Returns Depot), 3824 North 5th St., Suite C,
North Las Vegas, NV 89032**

Web Site: www.x10.com/support

VK75A-01/02

